

# Safety Advantages of On-Site Microprocesses

Fatemeh Ebrahimi, Eero Kolehmainen,\* and Ilkka Turunen

Lappeenranta University of Technology, Department of Chemical Technology, P.O. Box 20, FIN-53851 Lappeenranta, Finland

## Abstract:

Usually large-scale capacities are preferred in process industry because of the economics of scale. However, small capacities bring along several other advantages, which are emphasized especially in on-site production. By producing on-site, the transportation of dangerous chemicals can be avoided. Moreover, smaller on-site production processes also mean a step towards inherently safer technology. Microreactors represent a technology that efficiently utilizes safety advantages resulting from small scale. These safety advantages of microreactors in on-site production are studied in this contribution. Production of peracetic acid is used as a test case. This unstable and explosive chemical is used, e.g. in treatment of municipal wastewater and pulp bleaching. This study is based on comparison of a conventional batch process with the capacity of 170 kg/h and an on-site continuous microprocess producing 10 kg/h peracetic acid. Preliminary design of these processes was carried out. Four different methods were used to analyze the safety of the processes. It was found that the conventional methods for analysis of process safety might not be reliable and adequate for radically novel technology, such as microprocesses. This is understandable because the methods are partly based on experience, which is very limited in the connection of totally novel technology.

## 1. Introduction

Safety of microreactors is based on a small reaction volume, which leads to small inventory of dangerous chemicals. In addition, the efficient heat transfer resulting from the high surface area-to-volume ratio, improves temperature control and, therefore, decreases the risk of run-away reactions. Thus, it is also possible to use higher operating temperatures safely. This increases the reaction rate and might lead to a smaller reaction volume. Microreactors have been applied successfully to many hazardous reactions such as fluorinations, chlorinations, oxidations, and brominations. Sometimes those reactions have been carried out at elevated temperature and pressure without safety problems.<sup>1–5</sup>

On-site production decreases the transportation and storage requirements of dangerous materials. This improves safety and may also reduce costs. On-site applications to produce peracetic

acid and hydrogen peroxide have been reported.<sup>6,7</sup> Also, on-site microreactor systems have been applied to the production of hydrogen.<sup>8–10</sup>

Applying microreactors to on-site production should combine the above-mentioned advantages and introduce new ones. This report attempts to demonstrate the advantages by comparing a conventional batch process and a continuous on-site microprocess to produce peracetic acid. Peracetic acid is an unstable substance because of thermal decomposition, and therefore, safety aspects in the production have to be emphasized.<sup>11</sup> Safety of the processes was studied by different safety evaluation methods. Preliminary design of these processes was carried out to enable the comparison.

In this study, four safety evaluation methods are applied: Reaction matrix,<sup>12</sup> Dow's Fire and Explosion Index,<sup>13</sup> Inherent Safety Index,<sup>14</sup> and Worst Case and Consequence Analysis.<sup>15</sup>

These methods are applied at different stages of design. At the preliminary design phase, the available information is limited. At this stage, however, the influence of the decisions is most important because they determine major features of the process. The reaction matrix reveals the undesirable combination of materials and is useful particularly early in the development of a new chemical processes.<sup>12</sup> Dow's Fire and Explosion Index is a suitable safety analysis method for the predesign (conceptual design) stage.<sup>13</sup> Inherent safety index can be applied at the R&D and process predesign stage.<sup>14</sup> Worst case and consequence analysis is a method to recognize the most harmful events and analyze their consequences.<sup>15</sup>

- (6) Vineyard, M. K.; Moison, R. L.; Budde, F. E.; Walton, J. R. Continuous process for on-site and on demand production of aqueous peracetic acid. U.S. Patent 7,012,154, 2006.
- (7) Brillas, E.; Alcaide, F.; Cabot, P. A. *Electrochem. Acta* **2002**, *48*, 331–340.
- (8) Patterkar, A. V.; Kothare, M. V.; Karnik, A. V.; Hatalis, M. K. IMRET 5, Strasbourg, France, May 27–30, 2001; *Proceedings of the 5th International Conference on Microreaction Technology*; Springer-Verlag: Berlin, 2001.
- (9) Cristian; Mitchell, M.; Kenis, P. J. A. *Lab. Chip* **2006**, *6*, 1328–1337.
- (10) Cristian; Mitchell, M.; Kim, D. P.; Kenis, P. J. A. *J. Catal.* **2006**, *241*, 235–242.
- (11) Swern, D. *Organic Peroxides*; Wiley Interscience: New York, 1970; Vol. 1.
- (12) McKetta, J. J.; Anthony, R. G.; McKetta, J. J.; Cunningham, W. A. *Encyclopedia of Chemical Processing and Design*, 2002.
- (13) *Dow's Fire & Explosion Index Hazard Classification Guide*, 7th ed., AIChE Technical Manual; American Institute of Chemical Engineers: New York, 1994.
- (14) Heikkilä, A. M. Inherent safety in process plant design, PhD Thesis; Technical Research Centre of Finland, VTT publications 385: Espoo, 1999.
- (15) Flynn, A. M.; Theodore, L. *Health, Safety, and Accident Management in the Chemical Process Industries: A Complete Compressed Domain Approach*; Chemical Industries, Vol. 86; CRC Press: Boca Raton, FL, 2001.

\* Corresponding author. Telephone: +358-5-6216128. Telefax: +358-5-6212199. E-mail: Eero.Kolehmainen@lut.fi.

- (1) Ehrfeld, W.; Hessel, V.; Löwe, H. *Microreactors: New Technology for Modern Chemistry*; Wiley-VCH: Weinheim, 2000.
- (2) Hessel, V.; Hardt, S.; Löwe, H. *Chemical Microprocess Engineering: Fundamentals, Modelling and Reactions*; Wiley-VCH: Weinheim, 2004.
- (3) Löb, P.; Löwe, H.; Hessel, V. *J. Fluorine Chem.* **2004**, *125*, 1677–1694.
- (4) Vesper, G. *Chem. Eng. Sci.* **2001**, *56*, 1265–1273.
- (5) Inoue, T.; Schmidt, M. A.; Jensen, K. F. *Ind. Eng. Chem. Res.* **2007**, *46*, 1153–1160.

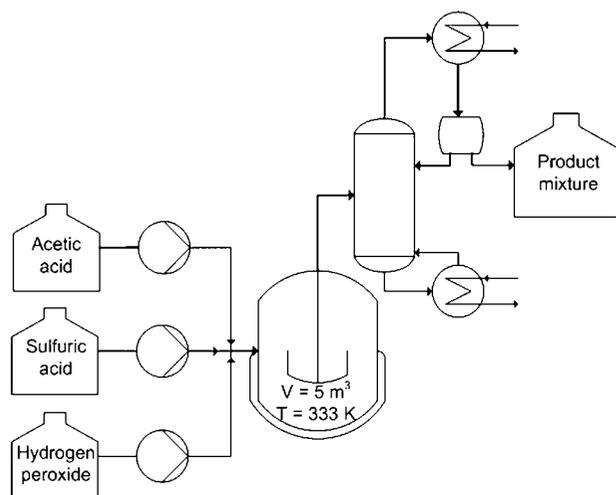

**Figure 1.** Simplified process flow diagram for the conventional batch process.

## 2. Production of Peracetic Acid

Production of peracetic acid was used as an example reaction in this comparison. Peracetic acid is a strong oxidant, which is used e.g., as a disinfection or bleaching agent. It can be prepared from acetic acid and hydrogen peroxide. The equilibrium reaction is catalyzed by sulfuric acid. Water is also present in the system.<sup>11</sup> The reaction is shown in eq 1.

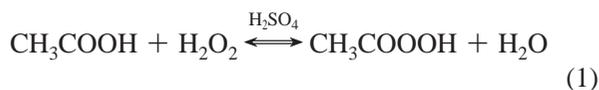

For many oxidations, only low concentrations of peracetic acid are needed, and equilibrium mixtures can be used directly.<sup>11</sup> For example, in wastewater disinfection, the concentration of 15 mg/L (peracetic acid in wastewater) leads to efficient elimination of microbes.<sup>16,17</sup> In production and handling of peracetic acid, attention should be paid to conditions and concentrations to minimize the risk of thermal decomposition.

**2.1. Conventional Batch Process.** Typically, peracetic acid is produced in a stirred tank reactor, which is connected to a distillation unit. Sulfuric acid is first fed into the reactor, and then acetic acid and hydrogen peroxide are added. The mixture is heated to 60 °C at which temperature the reaction takes place. After the reaction stage, pressure in the reactor is decreased to a pressure of 3–17 kPa. Vaporization of the reaction mixture begins. Acetic acid, hydrogen peroxide, and peracetic acid are separated from the sulfuric acid in a distillation column. The sulfuric acid remains in the reactor. Production capacity of peracetic acid in this process is 170 kg/h (based on a 5 m<sup>3</sup> reactor with the total charging, reaction, and separation time of 3.5 h). A simplified process flow diagram for the conventional batch process is shown in Figure 1.

**2.2. On-Site Microprocess.** The on-site microprocess represents here a continuous production mode. A simple block diagram is shown in Figure 2. The process includes two mixing steps. In the first, (mixing I), acetic acid and sulfuric acid are mixed. In the second, (mixing II), hydrogen peroxide is added to the mixture. After leaving the reactor, the equilibrium

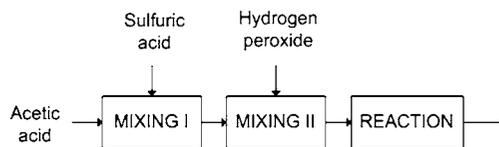

**Figure 2.** Block diagram of the continuous microscale process.

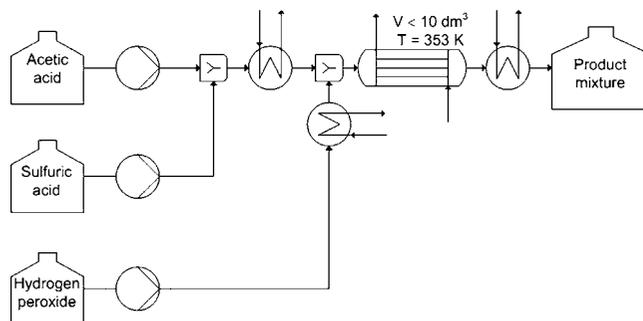

**Figure 3.** Simplified process flow diagram for the continuous microprocess.

mixture, which contains acetic acid, hydrogen peroxide, peracetic acid, sulfuric acid, and water, is ready for further use or treatment.

The microscale reactor concept consists of a multichannel reactor unit, which includes submillimeter-sized channels (0.25 mm). In this reactor, more efficient heat transfer can be achieved than in a stirred tank reactor. Therefore, the reaction can be performed safely at higher temperatures with a higher reaction rate. Microreactors can be built to be mechanically strong, and they can tolerate high pressures. Production capacity of peracetic acid in the on-site microprocess is 10 kg/h (based on a microreactor with the internal volume less than 10 dm<sup>3</sup>. The reaction time in the system is less than 300 s). It is assumed that one on-site microprocess serves one application, e.g., a wastewater treatment plant. For comparison, one conventional batch process with the capacity of 170 kg/h serves 15–20 centralized similar plants. A simplified process flow diagram for the microprocess is shown in Figure 3.

## 3. Safety Evaluation Results

**3.1. Reaction Matrix.** The reaction matrix is an interaction matrix, which is a useful tool to predict desired and undesired reactions and interactions between all the materials in the process.<sup>18</sup> It is particularly valuable in the development stage of a new chemical process. In this study, results show similar incompatibilities in both processes. The essential factors such as size of equipment and quantity of chemicals are not taken into account in this method. The reaction matrix does not reveal any differences in the safety of the microreactor and the conventional process.

**3.2. Dow's Fire and Explosion Index.** Dow's Fire and Explosion index is a stepwise evaluation of the realistic fire, explosion, and reactivity potential of a process. The accurate

(16) Kitis, M. *Environ. Int.* **2004**, *30*, 47–55.

(17) Koivunen, J.; Heinonen-Tanski, H. *Water Res.* **2005**, *39*, 4445–4453.

(18) Mosley, D. W.; Ness, N.; Hendershot, D. C. 34th Annual Loss Prevention Symposium, Atlanta, GA, March 5–9, 2000, Tools for Understanding Reactive Chemical Hazards Early in Process Development. *Proceedings of the 34th Annual Loss Prevention Symposium*; American Institute of Chemical Engineers: New York, 2000; Paper LPS 3d (45d).

**Table 1.** Dow's Fire and Explosion Index for the conventional batch process and continuous on-site microprocess

	conventional process	on-site microprocess
process unit risk analysis		
material factor for peracetic acid	40	40
<b>Fire and Explosion Index(F&amp;EI)</b>	<b>226</b>	<b>112</b>
radius of exposure [m]	58	29
area of exposure [m <sup>2</sup> ]	1.05 × 10 <sup>4</sup>	0.26 × 10 <sup>4</sup>
value of area of exposure [\$]	5 × 10 <sup>6</sup>	5 × 10 <sup>5</sup>
damage factor [-]	0.95	0.80
actual maximum probable property damage [\$]	5 × 10 <sup>6</sup>	4 × 10 <sup>5</sup>
maximum probable days outage [day]	75	35

plot plan of the plant and the process flow diagram are needed in the evaluation. The evaluation is based on the penalties and factors, which are judged according to reaction and substance characteristics, material handling, operational conditions, and equipment characteristics. The obtained index and factors are used in determining the area of exposure and probable property damages.<sup>13</sup> The summary of the process risks and the comparison between microprocess and conventional process is presented in Table 1.

Fire and Explosion Index (F&EI) is used for estimating the damage that would probably result from an incident in a process plant. According to F&EI, the degree of hazard in the microprocess is intermediate, and in the conventional process severe. The radius and area of exposure describe the region where equipment can be exposed to a fire or an explosion. The microprocess shows a much smaller area of exposure. The damage factor represents the overall effect of fire and explosion damage resulting from a release of reactive energy from a process unit. According to Table 1, damage factor is smaller for microprocess. The maximum value is 1. The value of the area of exposure is obtained by cost estimation for the replacement of major equipment and the inventory of material. Actual maximum probable property damage represents the property damage that could result from an incident while control systems are functioning. This value is a function of the damage factor, and therefore, it is smaller for the microprocess. Maximum probable days outage represents the time needed to repair the process after the incident. It depends on the availability of the equipment and also the ability for installation. As a result, it determines the business interruption after the incident. For the microprocess, the outage period is shorter than for the conventional process. However, if a microreactor is damaged, it can be assumed that replacement of such a reactor requires a longer time than in the case of the conventional process. In the conventional process, a stirred tank and other units represent standard reactor technology which is more readily available.

To summarize, this evaluation method indicates that here the on-site microprocess is much safer than the conventional batch process. However, the different sizes of equipment of these two processes have not been taken fully into account in this method. The index for microprocess was expected to be clearly lower because of lower production capacity and smaller liquid volumes than in conventional process. The evaluation-

**Table 2.** Index determination table for inventories<sup>14</sup>

inventory		score of
ISBL	OSBL	I <sub>I</sub>
0–1 t	0–10 t	0
1–10 t	10–100 t	1
10–50 t	100–500 t	2
50–200 t	500–2000 t	3
200–500 t	2000–5000 t	4
500–1000 t	5000–10000 t	5

**Table 3.** Index determination table for equipment items<sup>14</sup>

equipment itemsfor ISBL	score of I <sub>EQ</sub>
equipment handling nonflammable, nontoxic materials	0
heat exchangers, pumps, towers, drums	1
air coolers, reactors, high hazard pumps	2
compressors, high hazard reactors	3
furnaces, fired heaters	4

method is based on conventional processes and large-volume production. Often the quantity of chemicals in microreactors is substantially smaller; therefore, some definitions of the penalties are not taking into account such small sizes of microreactors.

**3.3. Inherent Safety Index.** Heikkilä has developed an inherent safety index method for conceptual chemical process design.<sup>14,19</sup> A numerical index for the studied process is determined, and the total safety of the process is evaluated by comparing it with a reference process.

In the original method, the total inherent safety index is divided into chemical inherent safety index  $I_{CI}$  and process inherent safety index  $I_{PI}$ , which both represent a sum of inherent safety subindexes (eq 2).

$$I_{TI} = I_{CI} + I_{PI} \quad (2)$$

Since the comparison is made now between two process types producing the same product via a similar reaction route, the sum of chemical inherent safety subindexes, i.e., reaction heats, flammability, explosiveness, toxicity, corrosiveness, and chemical interaction indexes, will be similar for both processes. Therefore, the differences between total inherent safety indexes of the processes are explained only by process inherent safety index (eq 3):

$$I_{PI} = I_I + I_{T,max} + I_{p,max} + I_{EQ,max} + I_{ST} \quad (3)$$

This index considers the size of inventories, operating temperature and pressure, equipment items, and process structure. The scores for the inherent safety subindexes are determined in index determination tables.<sup>14</sup> Examples of such tables for inventories and equipment items are presented in Tables 2 and 3.

Similar index determination tables are used for all subindexes. The breakdown of the total inherent safety index for the conventional batch process and the continuous on-site microprocess is shown in Table 4. Lower index values refer to a process with built-in safety.

This method indicates that the conventional batch process is safer than the on-site microprocess. When determining the

(19) Heikkilä, A. M.; Hurme, M.; Järveläinen, M. *Comput. Chem. Eng.* **1996**, *20*, S115–S120.

**Table 4. Inherent process safety subindexes for the conventional batch process and continuous on-site microprocess**

safety subindex	conventional batch process	score	continuous on-site microprocess	score
inventory (OSBL), $I_I$	100–500 t	2	0–10 t	0
process temperature, $I_{T,max}$	60 °C	0	80 °C	1
process pressure, $I_{p,max}$	1 bar	0	5 bar	1
equipment safety (max of ISBL or OSBL), $I_{EQ,max}$	reactor	2	reactor	2
process structure, $I_{ST}$	sound engineering practice	1	no data or neutral	2
total inherent safety index, $I_{TI} = I_{CI}$		5		6

**Table 5. Summary of the worst case and consequence analysis**

categories of the worst cases and consequences	worst case	consequences
1. material release	run-away or unpredicted chemical reactions	explosion
2. operating conditions, temperature and pressure	malfunction of heat exchanger, clogging	heat accumulation, run-away reactions, pressure rise, explosion, release of material
3. process equipment	severe corrosion	explosion, release of dangerous material
4. transportations	damage of material tank	release of material to environment, pollution, explosion
5. unpredictable factors	flood, tornado, earthquake, terrorism	release of material, explosion, fire

equipment safety index (Table 4), the type of reactor is not specified in the method. The inherent safety index does not take into account the size of the reactor that inevitably makes microprocess intrinsically safer due to small internal volumes and efficient temperature control. It is clear that the reactor technology has a significant effect on the inherent safety of any process.

Process structure subindex (Table 4) favors standard and well-known processes and equipment. Novel processes, such as microreactors, suffer in this method, although they might represent safer technology. Also, the method does not take into account the risks in chemical transport that is mostly eliminated in on-site production.

Because of the above-mentioned aspects, the results may be misleading. It can be concluded that the inherent safety index is more suitable for safety evaluation of conventional technology than of novel processes.

**3.4. Worst Case and Consequence Analysis.** Worst-case-scenario analysis can be used to study the worst cases and the associated consequences. For the peracetic acid process, the worst cases and their consequences are classified into five categories which are materials, operating conditions, process equipment, transportation, and other factors. Summary of analysis is shown in Table 5.

Usually the worst cases refer to explosion or releases. Release of hazardous toxic materials may cause serious jeopardy to the surrounding area.<sup>20</sup> Here, explosion risk is often relevant because of the unstable nature of reactants. Comparison between the processes is presented in Table 6 by using the safety grades.

Due to the intrinsic advantages of the on-site manufacturing of peracetic acid with a microprocess, it can be expected that the safety of the on-site microprocess would be clearly higher compared to that of the centralized conventional batch process. Therefore, the hazardous consequences of some worst cases are also expected to be significantly milder.

**Table 6. Comparison of worst cases and consequences for the process alternatives<sup>a</sup>**

categories of the worst cases and consequences	conventional batch process	continuous on-site microprocess
1. material release	4	2
2. operating conditions	2	2
3. process equipment	4	3
4. transportations	5	1
5. unpredictable factors	4	2
in total	19	10

<sup>a</sup> 5 - Very Serious Hazard, 4 - Serious Hazard, 3 - Medium Hazard, 2 - Small Hazard, 1 - No Hazard.

Based on the worst cases analysis for the peracetic acid production, the inherent safety improvement is one of the major driving forces to develop on-site microprocesses to replace conventional continuous processes with substantial safety risks.

## 4. Conclusions

Safety study involved a comparison of an on-site microprocess and a conventional centralized batch process for production of peracetic acid. The safety was evaluated by using four methods: the reaction matrix, Dow's Fire and Explosion Index, the inherent safety index, and worst case and consequence analysis.

The reaction matrix describes systematically the interactions between all the compounds and materials involved in a process. The aim is to identify possible incompatibilities between materials. Basically, this method did not reveal any differences between production modes. The method does not take into account the differences in size and transportation needs. Dow's Fire and Explosion Index established the safety advantages of the on-site microprocesses, which were attributable to the smaller liquid volumes in the processes and reduced storage requirements. However, the method does not fully take into account the dramatically smaller internal volumes of the on-site microprocess. The inherent safety index clearly favored the conventional production technology, suggesting that it is safer than the microprocess. This result is misleading, and thus the

(20) Kleindorfer, P. R.; Belke, J. C.; Elliott, M. R.; Lee, K.; Lowe, R. A.; Feldman, H. I. *Risk Anal.* **2003**, *23*, 865–881.

method is not reliable here. Worst case and consequence analysis clearly indicated a higher safety for the on-site microprocess. With this method, it was possible to emphasize the relevant characteristics of the processes, such as transportation needs and size differences. It is also applicable to the evaluation of totally novel processes.

Most of the conventional methods for safety evaluation are based, at least partly, on experience. Therefore, they are not at their best in the connection of novel technology, such as microreactors.

Microreactors have plenty of advantages from safety viewpoint, when compared to conventional production technologies. These advantages are mostly based on radically smaller reaction volumes and effective heat transfer, which allow a fast temperature control. The safety advantages of microreactors can be effectively utilized in on-site production, because it eliminates transportation and storage of hazardous chemicals.

As a conclusion, conventional quantitative safety methods do not take fully into account the safety advantages of microreactors. Some important safety advantages are neglected, such as liquid volumes, surface-to-volume ratio, on-site utilization, and mass of construction material to reaction volume ratio, which means mechanical strength of a reactor.

## Acknowledgment

Financial support from Finnish Graduate School of Chemical Engineering (GSCE) and Finnish Funding Agency for Technology and Innovation (Tekes) are gratefully acknowledged.

## Nomenclature

$I_{CI}$	chemical inherent safety index
$I_{EQ,max}$	index for equipment safety
$I_I$	index for inventory (ISBL or OSBL, inside or off-site battery limit area)
$I_{PI}$	process inherent safety index
$I_{p,max}$	index for process pressure
$I_{ST}$	index for process structure
$I_{TI}$	total inherent safety index
$I_{T,max}$	index for process temperature

Received for review April 2, 2009.

OP900079F